

**ADxC-DC-38-001**

## Steerable Tail Wheel for Schempp-Hirth Ventus cM

**Description:**

The steerable tail wheel for the motor glider Ventus cM is an upgrade for the non-steerable Schempp-Hirth tail wheel.

The EASA-approved STC can be installed by any suitably approved maintenance organisation that has the Ventus cM within its scope. Additional mass is 1.4kg.

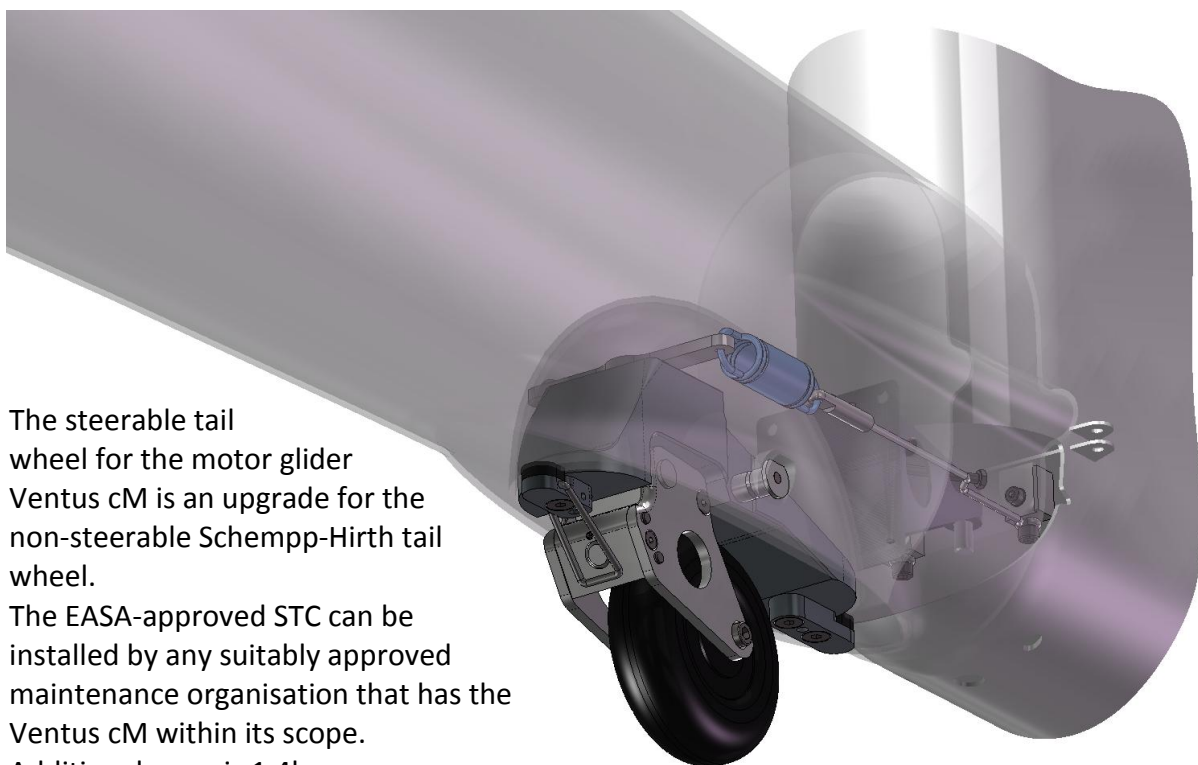

**Features:**

- Improved controllability on the ground
- Autonomous taxiing capability
- At any time after initial installation, the steerable tail wheel can be replaced with the non-steerable one.
- No influence on performance, limitations and recommended speeds

**Contact:**

for more information, contact us at: [info@aircraftdc.de](mailto:info@aircraftdc.de).  
[www.aircraftdc.de](http://www.aircraftdc.de)

